

# WMIOT602 Specification

V1.0.0

Beijing Winner Microelectronics Co., Ltd.

Address: 18th floor, Yindu Building, No.67 Fuchen Road, Haidian District, Beijing, P.R.China

Tel: +86-10-62161900

Company Website: [www.winnermicro.com](http://www.winnermicro.com)

### Document history

Version	Completion Date	Revision Record	Author	Auditor	Approver
V1.0.0	2018-05-02	Initial release	Janvense	Kevin	Kevin

Winner Micro

## Content

1	Summary.....	1
2	Features.....	1
2.1	Interface.....	1
2.2	Wi-Fi .....	1
2.3	Others .....	2
3	Specification .....	2
4	Antenna specification .....	3
5	Interface signals.....	3
6	Environmental adaptability.....	4
6.1	Low temperature working test.....	4
6.2	Low temperature storage test.....	4
6.3	High temperature working test .....	4
6.4	High temperature storage test.....	5
6.5	Vibration test .....	5
6.6	Environment protection certificate.....	5
7	Reference design.....	5

Winner Micro

## 1 Summary

WMIOT602 is a Wi-Fi reference design module based on embedded Wi-Fi SoC chip (W600), which has stamp hole interface, small size and is easy to develop. The module can be easily applied to smart appliances, smart home, health care, smart toy, and wireless audio & video, industrial and other IoT fields. This specification provides technical standards for the physical properties, technical specifications, communication protocols, product functions, performance, stability, environmental adaptability, and security of the module.

## 2 Features

### 2.1 Interface

- stamp hole interface, spacing 2.0mm
- Integrated 2 UART interface, support RTS/CTS, baud rate: 1200bps~2Mbps
- Integrated one high speed SPI controller, operating frequency: 0~50MHz
- Integrated GPIO controller

### 2.2 Wi-Fi

- Support GB15629.11-2006、IEEE802.11 b/g/e/i/d/k/t/s/w/n
- Support frequency range: 2.4~2.4835 GHz
- Support Wi-Fi WMM/WMM-PS/WPA/WPA2/WPS
- Support Wi-Fi Direct
- Support EDCA channel access
- Support 20/40M bandwidth
- Support STBC, Greenfield, Short-GI and reverse transmission
- Support RIFS interframe space
- Support AMPDU、AMSDU
- Support IEEE802.11n MCS 0~7, MCS32, transmission rate is up to 150Mbps
- Support Short Preamble in 2/5.5/11Mbps
- Support HT-immediate Compressed Block Ack, Normal Ack, No Ack
- Support CTS to self
- Support STA/AP/AP+STA function
- Support up to 32 multicast networks with different encryption methods in BSS
- As AP in BSS, the sum of sites and groups is up to 32 and in IBSS is up to 16

## 2.3 Others

- Programmable GPIO control signals
- Support AT+ instruction protocol(UART interface) base on ASCII
- Support network protocol: TCP/UDP/ICMP/DHCP/DNS/HTTP
- Support DHCP Server, DNS Server
- Support extensible WEB server
- Support firmware on line update

## 3 Specification

**Table 3-1 product specification list**

	item	parameter	comment
Wi-Fi	Support Wi-Fi protocol	IEEE802.11b/g/n	
	RF system impedance	50Ω	
	SWR	<-10dB	
	Frequency range	2.4~2.4835 GHz	
	Reception sensitivity	20MHz MCS7@-71dBm; 40MHz MCS7@-68dBm; 54Mbps@-73dBm; 11Mbps@-86dBm; 1Mbps@-95dBm;	
	Data rate in PHY	802.11n MCS 0~7 150Mbps	
	Modulation mode	DSSS、OFDM、DBPSK、DQPSK、CCK、QAM16/64	
	Output power	IEEE802.11b, CCK 11Mbps, POUT = +19 dBm; IEEE802.11g, OFDM 54Mbps, POUT = +13.5 dBm; IEEE802.11n, OFDM MCS7, POUT = +12dBm;	
Hardware	Interface	UART、SPI、GPIO	
	Data rate	2Mbps@UART (Max) 50Mbps@SPI (Max)	
	Working voltage	3.3V	
	Working current	110mA (PS Mode 35mA, DTIM=1)	
	Working humidity	5%~90% (no condensation)	
	Storage temperature	-40~+125 °C	
	Working temperature	-40~+85°C	

	Size	10mm×12mm	
Software	Network type	STA/AP/AP+STA/Wi-Fi Direct	
	Authentication	WEP/WPA-PSK/WPA2-PSK	
	Encryption	WEP64/WEP128/TKIP/CCMP(AES)	
	WPS	WPS	
	Energy conservation	PS-POLL/Standby	
	Network protocol	TCP/UDP/ARP/ICMP/DHCP/DNS/HTTP	
	Interface protocol	AT+ instruction	

#### 4 Antenna specification

**Table 4-1 recommended specification for external antenna**

item	comment
Frequency range	2.4~2.4835 GHz
Impedance	50 Ω
Voltage standing-wave ratio	≤1.5
Polarization	Linear polarization
Interface	IPX

#### 5 Interface signals

WMIOT602 is shown in Figure 5-1:

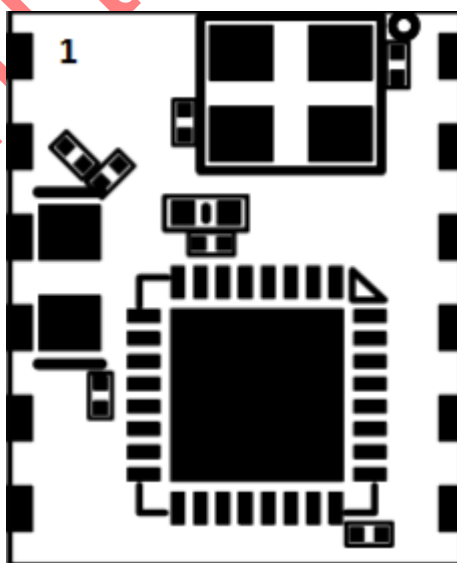

**Figure 5-1 WMIOT602**

The pin description is shown in Table 5-1:

**Table 5-1 Pin Description**

Pin No.	Pin Name	Type	Default function description	Multi-Function
1	GND	P	GND	
2	ANT	ANT	Antenna	
3	GND	P	GND	
4	VCC	P	3.3V Power	
5	PA_4	I/O	UART0_TX	
6	PA_5	I/O	UART0_RX	
7	PB_8	I/O	GPIOPB_8	H_SPL_CLK
8	PB_9	I/O	UART1_CTS	H_SPL_INT
9	PB_10	I/O	UART1_RTS	H_SPL_CS
10	PB_11	I/O	UART1_RX	H_SPL_DI
11	PB_12	I/O	UART1_TX	H_SPL_DO
12	RST	I	Reset by Low Power	

## 6 Environmental adaptability

### 6.1 Low temperature working test

- Reference standard: GB/T 2423.1-2001;
- Under the ambient temperature is  $-40\pm 1^{\circ}\text{C}$ , the sample of the module can continuously work for 72 hours, and all the functions and functions are well maintained after the test.

### 6.2 Low temperature storage test

- Reference standard: GB/T 2423.1-2001
- Under the ambient temperature of  $-40^{\circ}\text{C}$ , the sample of the module is placed for 72 hours, and all the functions and functions are well maintained after the test.

### 6.3 High temperature working test

- Reference standard: GB/T 2423.2-2001
- Under the ambient temperature is  $85\pm 1^{\circ}\text{C}$ , the sample of the module can continuously work for 72 hours, and all the functions and functions are well maintained after the test.

#### 6.4 High temperature storage test

- Reference standard: GB/T 2423.2-2001
- Under the ambient temperature of 125°C, the sample of the module is placed for 72 hours, and all the functions and functions are well maintained after the test.

#### 6.5 Vibration test

- Reference standard: GB/T 4798.5-2007
- Random vibration, vibration direction: X, Y and Z axis, displacement and frequency refer to 5M3 level in GB/T 4798.5-2007, vibration time: each axis 60min. In detail, please refer to 5M3 level in GB/T 4798.5-2007.

#### 6.6 Environment protection certificate

- Conform to the RoHS IEC62321-1:2013 standard

#### 7 Reference design

The reference design is shown in Figure 7-1:

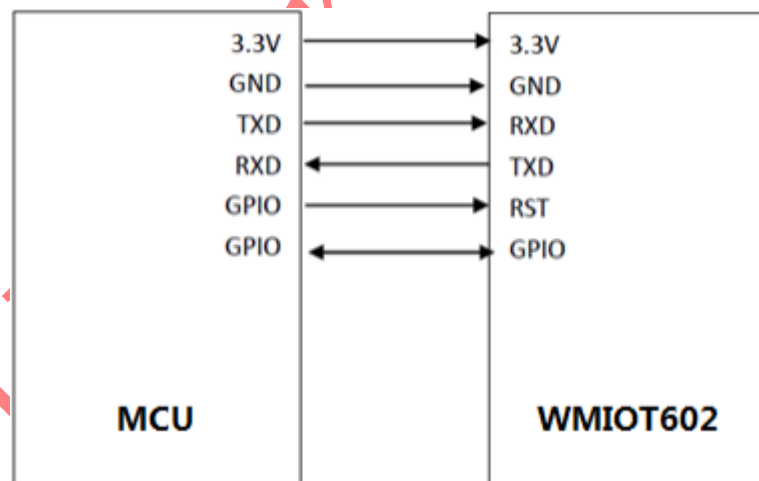

Figure 7-1 WMIOT602 reference design